

Industrial Range

MODEL

**BGH2600**

DUAL RANGE TESTER



Hydraulic  
Dead-Weight  
Testers

Primary standards  
for Pressure  
Calibration

▶ Range from  
1 - 2600 bar

▶ Standard Accuracy  
to 0.02%

▶ Class 'A' Accuracy  
to 0.01%

▶ Supplied with  
integral pressure  
generation



Budenberg

# Industrial Range

## MODEL BGH2600

### DUAL RANGE TESTER

## Hydraulic Dead-Weight Testers

## Primary standards for Pressure Calibration

Standard Accuracy to 0.02%  
Class A  
Calibration Certificate 0.01%

RANGES:  
2,600 bar 40,000 psi  
2,600 kg/cm<sup>2</sup> 260 MPa

### ACCURACY

All certificates issued for Budenberg Dead Weight Testers are fully traceable to national standards via equipment with UKAS calibration certificates. The standard accuracy of 0.02% is achieved between 6 and 1200 bar using software supplied to allow the user to compensate for the effects of gravity and temperature. In other parts of the pressure range, the standard accuracy is 0.025% from 1 to 6 bar, 0.03% from 1200 to 1800 bar and 0.04% from 1800 to 2600 bar. Higher accuracy Class A testers are available supplied with detailed Area and Mass certificate of calibration allowing an accuracy of 0.01% to be achieved from 6 to 2600 bar.

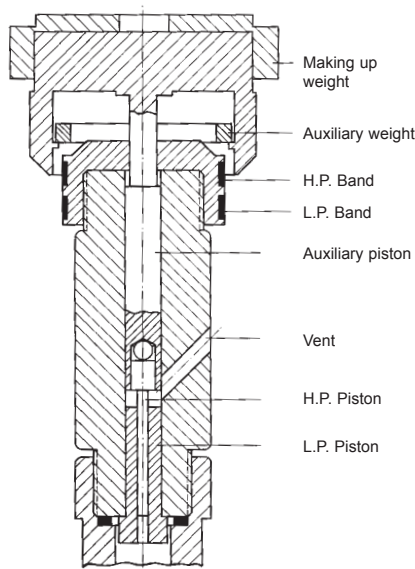

### BGH2600 SERIES BASE

The base features a high pressure dual area screw-press which allows for low pressure priming and high pressure control. The base incorporates high pressure hydraulic connections and pipework, connected to a gauge stand which uses Budenberg's standard high pressure cone-joint connections. The piston stand is elevated from the base to allow an overhang weight set to be used, giving extra stability at higher pressures. Additional support is provided in the base by means of five adjustable feet, one of which directly supports the piston and mass set. The BGH2600 uses a well-proven patented design in its dual area piston/cylinder unit with 1/8in<sup>2</sup> and 1/160in<sup>2</sup> areas. Changing between ranges is fully automated, meaning that users have an extremely flexible instrument covering the range with one piston/cylinder assembly and one weight set. The low pressure piston/high pressure cylinder is tungsten carbide, other parts are fully hardened and stabilised tool steel.

Please note: Due to Budenberg's policy of continuous improvements, specifications may be subject to change without notice.

### WEIGHTS SUPPLIED

bar or kg/cm <sup>2</sup>	MPa	lb/in <sup>2</sup>
Low range (**)	Low range (**)	Low range (**)
1 - 50	0.1 - 5	10 - 600
High range	High range	High range
20 - 2600	2 - 260	200 - 40000
Piston 1 or 20 top loading	Piston 0.1 or 2 top loading	Piston 10 or 200 top loading
1 wt 9 or 180 top loading	1 wt 0.9 or 18 top loading	1 wt 90 or 1800 top loading
3 wts 10 or 200 top loading	3 wts 1 or 20 top loading	4 wts 100 or 2000 top loading
1 wt 5 or 100 top loading	1 wt 0.5 or 10 top loading	1 wt 50 or 1000 top loading
2 wts 2 or 40 top loading	2 wts 0.2 or 4 top loading	2 wts 20 or 400 top loading
1 wt 1 or 20 top loading	1 wt 0.1 or 2 top loading	1 wt 10 or 200 top loading
2 wts 0.5 or 10 top loading	2 wts 0.05 or 1 top loading	1 wt 5 or 100 top loading
Overhang & m.u.wt 10 or 200	Overhang & m.u.wt 1 or 20	Overhang & m.u.wt 100 or 2000
7 wts 10 or 200 annular	7 wts 1 or 20 annular	14 wts 100 or 2000 annular

\*\* Use Top Loading weights on low range only

### ACCESSORIES

There are many accessories which can be supplied for use with the Dead-weight testers. Budenberg have extensive experience in the use of Dead-weight testers and can supply accessories for many applications.

### PACKING DETAILS

1 carton containing base, tool roll and piston unit:  
59 x 49 x 38cm, 0.110m<sup>3</sup>, Nett 20kg, Gross 22kg.  
Up to 5 cartons containing weights:  
32 x 32 x 31cm, 0.04m<sup>3</sup>, Nett 25kg, Gross 30kg. ea

### SPARES, REPAIR AND RE-CERTIFICATION

Comprehensive service and calibration capability of both Budenberg and non Budenberg test equipment: Dead-weight Testers (working service or full overhaul). Gauges (all types, all manufacturers). Portable calibrators (Budenberg & non-Budenberg). Comparators. All accuracy ranges can be supplied with UKAS Calibration Certificates. Certification traceable to national standards. Rapid turn-around times and hire items available as a temporary replacement for strategically important plant.

**For further information on Accessories, and other product information contact Budenberg and ask for a Data sheet.**

Budenberg Gauge Co. Ltd.  
Unit B2, Stuart Road,  
Altrincham Business Park,  
Altrincham WA14 5GJ,  
United Kingdom.

Tel: +44 (0)161 777 7300  
Email: sales@budenberg.co.uk  
Website: www.budenberg.co.uk

Budenberg Gauge Pvt. Ltd.  
299-300, IInd Main Road,  
Nehru Nagar,  
Old Mahabalipuram Road ( OMR ),  
Chennai - 600 096,  
Tamil Nadu , India

Tel : +91 44 24541074  
Tel/Fax: +91 44 24541075  
Email: sales@budenberg-gauge.in

Budenberg Gauge Asia  
Pacific Ltd

Unit 7A G/F Cheung Fat Ind  
Bldg 64-76 Larch St Tai Kok  
Tsui Kin  
Hong Kong

Tel : +852 3709 0020  
Email: sales@budenberg-gauge.asia

Budenberg Middle East LLC

PO Box 18980  
Dubai  
United Arab Emirates

Tel: +971 4 2511670  
Email: sales@budenberg-me.org

